

Werkzeugkatalog

tool catalogue

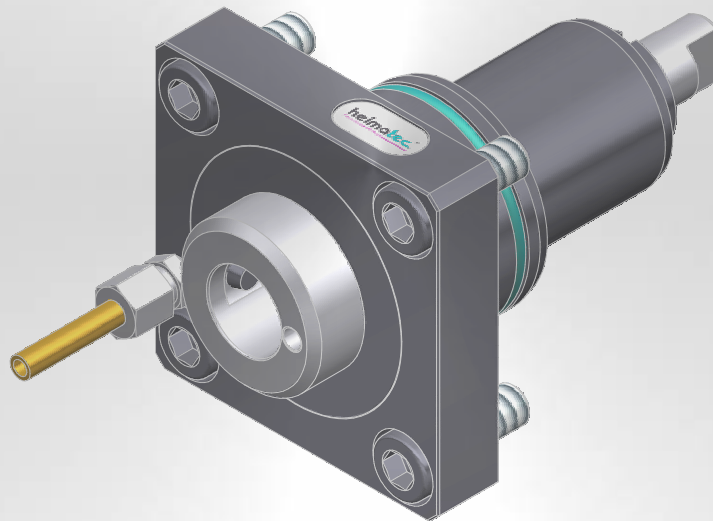

HYUNDAI WIA

L 230 LMSA



Hinweis zu den AGBs:

Diese finden Sie in unserem Internetauftritt unter

www.heimatec.de

Home/Impressum/AGB

Terms and conditions:

You will find them on our website

www.heimatec.com

Home/Imprint/Terms and Conditions

Das Katalog-Werk einschließlich aller seiner Teile ist urheberrechtlich geschützt. Jede Verwertung außerhalb der engen Grenzen des Urheberrechtsgesetzes ist ohne Zustimmung der Rechteeinhaber unzulässig und strafbar. Das gilt insbesondere für Vervielfältigungen, Übersetzungen, Mikroverfilmungen und die Einspeicherung und Verarbeitung in elektronischen Systemen.

heimatec® GmbH behält sich Änderungen technischer Art jederzeit ohne Vorankündigung vor. Dies gilt insbesondere bei Anpassungen an neue oder geänderte internationale Normen oder bei Weiterentwicklungen unserer Produkte oder Herstellungsprozesse.

This catalogue, including all its parts, is protected by copyright. Each use outside the restricted limitations of the Copyright Act is inadmissible and liable to prosecution without the consent of heimatec. This is particularly valid for duplication, translation, microfilming and feeding and processing in electronic systems.

heimatec® GmbH reserves the right of technical changes everytime without advance notice, which is particularly valid for adaptations to new or changed international standards, or to developments of our products or manufacturing processes.

angetriebene Werkzeuge
driven tools



Axial-Bohr- und Fräskopf
axial drilling and milling head

$n_{max} = 6000 \text{ min}^{-1}$

8 010 55 039	ER 25 AX u-tec	EK	1:1
8 010 55 038	ER 25 AX u-tec	IK 25 bar	1:1
8 010 55 057	ER 25 AX u-tec	IK 70 bar	1:1
8 010 56 039	ER 32 AX u-tec	EK	1:1
8 010 56 040	ER 32 AX u-tec	IK 25 bar	1:1
8 010 56 089	ER 32 AX u-tec	IK 70 bar	1:1
8 010 56 085	easy-quick HT 4	EK	1:1
8 010 56 086	easy-quick HT 4	IK 25 bar	1:1
8 010 56 087	easy-quick HT 4	IK 70 bar	1:1



Axial-Bohr- und Fräskopf kurze Ausführung
axial drilling and milling head short version

$n_{max} = 6000 \text{ min}^{-1}$

8 010 56 034	easy-quick HT 4	EK	1:1
8 010 56 035	easy-quick HT 4	IK 25 bar	1:1



Axial-Bohr- und Fräskopf
axial drilling and milling head

$n_{max} = 24000 \text{ min}^{-1}$

8 013 54 008	ER 16 AX u-tec	EK	1:4
8 013 54 009	ER 16 AX u-tec	IK 70 bar	1:4



Axial-Bohr- und Fräskopf
axial drilling and milling head

$n_{max} = 6000 \text{ min}^{-1}$

8 011 55 012	Kombidom/universal arbor 22	EK	1:1
8 011 55 017	Kombidom/universal arbor 1"	EK	1:1



Axial-Bohr- und Fräskopf
axial drilling and milling head

Achsversatz / offset A=42

8 019 54 022	ER 20 AX u-tec	EK	1:1
8 019 54 023	ER 20 AX u-tec	IK 140 bar	1:1
$n_{max} = 6000 \text{ min}^{-1}$			
8 019 54 024	ER 20 AX u-tec	EK	1:2
8 019 54 025	ER 20 AX u-tec	IK 140 bar	1:2
$n_{max} = 12000 \text{ min}^{-1}$			
8 019 54 026	ER 20 AX u-tec	EK	1:3
8 019 54 027	ER 20 AX u-tec	IK 140 bar	1:3
$n_{max} = 18000 \text{ min}^{-1}$			

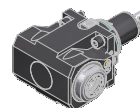
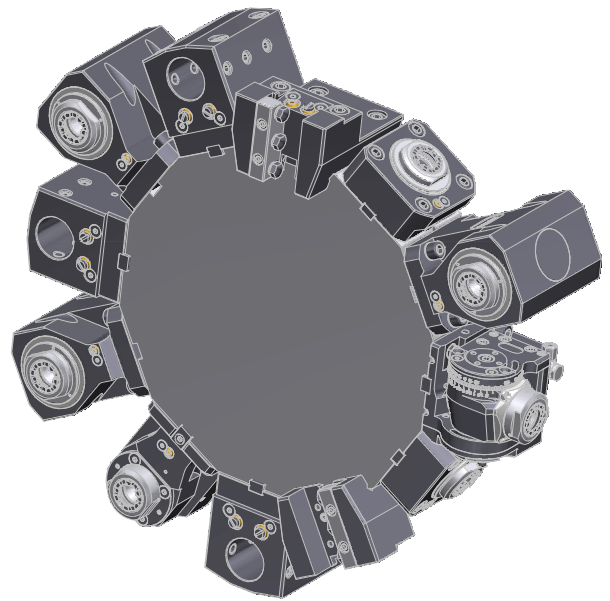

Winkel-Bohr- und Fräskopf
radial drilling and milling head

Mittenmaß / center distance H=85
 $n_{max} = 6000 \text{ min}^{-1}$

8 030 55 093	ER 25 AX u-tec	EK	1:1
8 030 55 098	ER 25 AX u-tec	IK 140 bar	1:1
8 030 56 099	easy-quick HT 4	EK	1:1
8 030 56 150	easy-quick HT 4	IK 140 bar	1:1

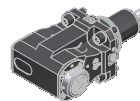

Axial-Bohr- und Fräskopf
axial drilling and milling head

Mittenmaß / center distance H=80

8 030 55 068	ER 25 AX u-tec	EK	1:2
8 030 55 066	ER 25 AX u-tec	IK 140 bar	1:2
$n_{max} = 12000 \text{ min}^{-1}$			
8 030 55 069	ER 25 AX u-tec	EK	1:3
8 030 55 067	ER 25 AX u-tec	IK 140 bar	1:3
$n_{max} = 18000 \text{ min}^{-1}$			



Winkel-Bohr- und Fräskopf
radial drilling and milling head

Mittenmaß / center distance H=85
 $n_{max} = 24000 \text{ min}^{-1}$

8 030 54 057	ER 16 AX u-tec	EK	1:4
8 030 54 058	ER 16 AX u-tec	IK 70 bar	1:4

► Weitere Ausführungen auf Anfrage
further versions on request

► Zubehör **ZB...***
accessories **ZB...***

► **easy-quick**

► **u-tec**

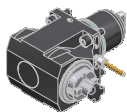

Winkel-Bohr- und Fräskopf radial drilling and milling head

Mittenmaß / center distance $H=85$
 $n_{max} = 6000 \text{ min}^{-1}$

8 031 55 025	Kombidorn/universal arbor 22	EK	1:1
8 031 55 026	Kombidorn/universal arbor 1"	EK	1:1



Winkel-Bohr- und Fräskopf radial drilling and milling head

Mittenmaß / center distance $H=85$
doppelspindlig / double spindle
 $n_{max} = 6000 \text{ min}^{-1}$

8 039 55 026	ER 25 AX u-tec	EK	1:1
8 039 56 028	easy-quick HT 4	EK	1:1



Schwenkkopf universal head

Mittenmaß / center distance $H=50$
Achsversatz / offset $A=35$

8 043 55 005	ER 25 AX u-tec	EK	1:1
8 043 55 009	ER 25 AX u-tec	IK 25 bar	1:1
$n_{max} = 6000 \text{ min}^{-1}$			
8 043 54 013	ER 16 AX u-tec	EK	1:2
8 043 54 014	ER 16 AX u-tec	IK 25 bar	1:2
$n_{max} = 12000 \text{ min}^{-1}$			



Winkel-Scheibenfräserkopf radial disk mill head

$\pm 30^\circ$ drehbar
 $\pm 30^\circ$ turnable

Mittenmaß / center distance $H=78$
auf 0° absteckbar / 0° can be pinned
kein Kühlmittel / no coolant
 $n_{max} = 4000 \text{ min}^{-1}$

8 037 54 013	$\varnothing 16$	2:1
8 037 54 014	$\varnothing 5/8"$	2:1

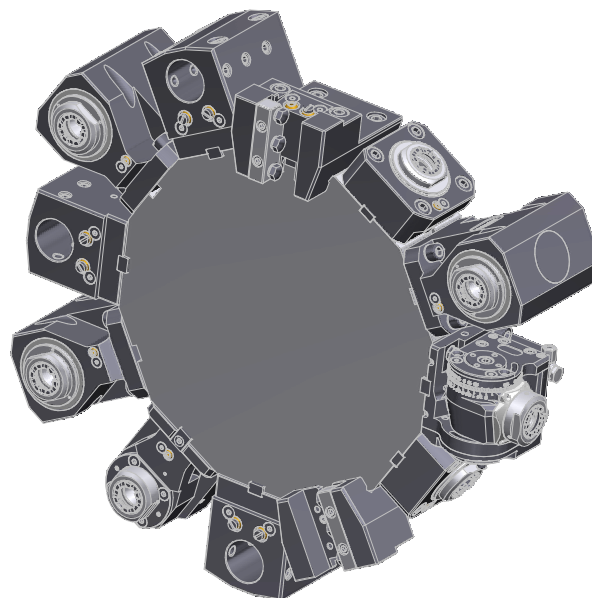

► Weitere Ausführungen auf Anfrage
further versions on request

► Zubehör ZB...*
accessories ZB...*



► easy-quick



► u-tec



feste Werkzeuge
static tool holders



Kombi-Drehstahlhalter
universal turning holder

8 224 05 003	Vierkant/square 25	EK
8 224 05 005	Vierkant/square 1"	EK

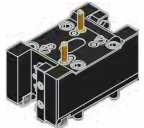

Kombi-Doppel-Drehstahlhalter
combi double turning holder

8 251 05 001	Vierkant/square 25	EK
8 251 05 003	Vierkant/square 1"	EK

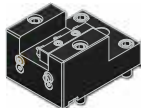

Kombi-Plandrehhalter
combi facing holder

8 244 05 003	Vierkant/square 25	EK
8 244 05 006	Vierkant/square 1"	EK

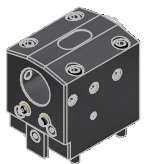

Bohrstangenhalter
boring bar holder

Mittenmaß / center distance H=95

8 240 08 026	ø32	IK/EK
8 240 08 028	ø40	IK/EK
8 240 08 027	ø1 1/4"	IK/EK
8 240 08 029	ø1 1/2"	IK/EK

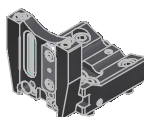

Abstechhalter
cut-off holder

höhenverstellbar / height adjustable

8 320 03 008	SH 32	IK 70 bar
--------------	--------------	-----------

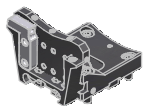

Abstechhalter
cut-off holder

höhenverstellbar / height adjustable



8 320 09 001	HORN System 845	IK 70 bar
--------------	------------------------	-----------

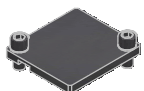

Abdeckblech
cover plate

8 200 52 001

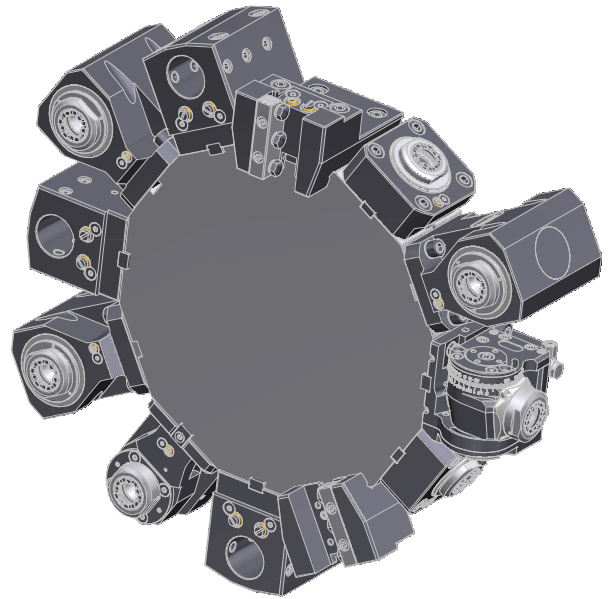

HYUNDAI WIA L 230 LMSA

▶ Weitere Ausführungen auf Anfrage
further versions on request

▶ Zubehör **ZB...***
accessories **ZB...*** 

▶ **easy-quick** 

▶ **u-tec** 

► **easy-quick HT Schnellwechselsystem**
easy-quick HT fast change system

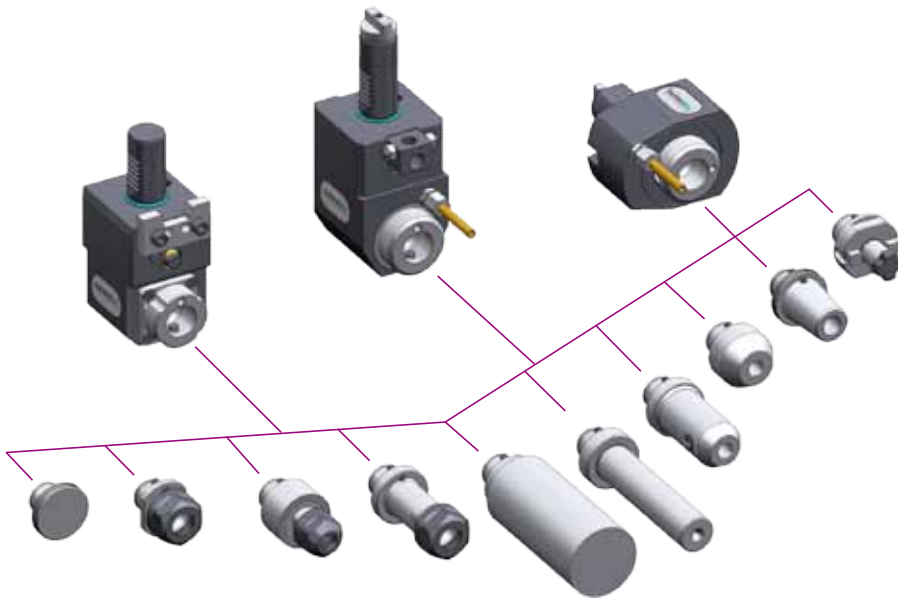

DAS Schnellwechselsystem von heimatec
für angetriebene und feste Werkzeuge

*THE fast change system of heimatec
for driven and static tools*

www.heimatec.de
Produkte / easy-quick

www.heimatec.com
products / easy-quick

► Ausführungen siehe Katalog
versions see catalogue



► **u-tec[®] UT Wechselsystem**
u-tec[®] UT change system

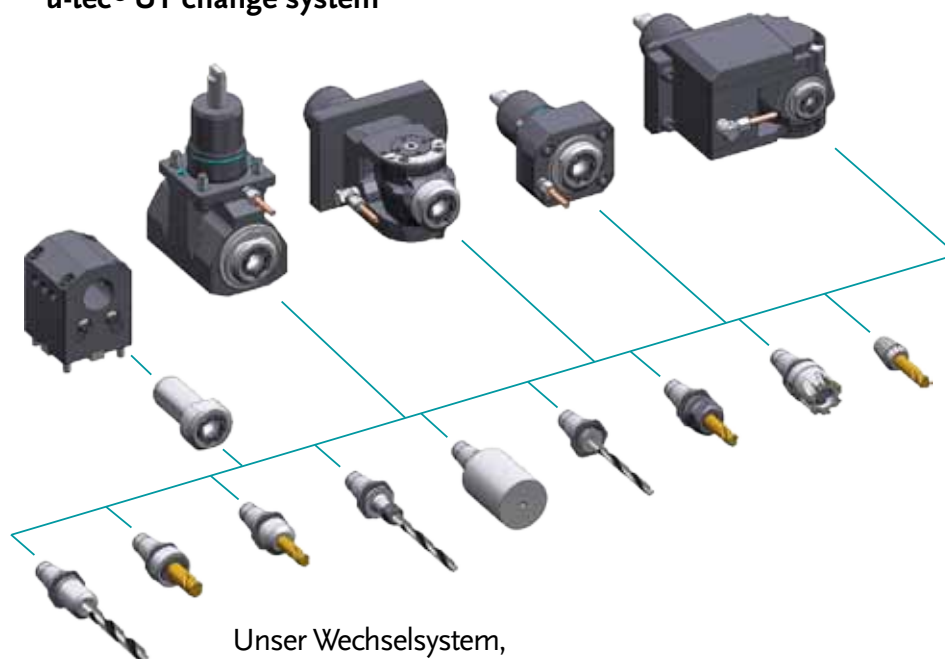

Unser Wechselsystem,
das ALLES möglich macht

Our change system,
that makes EVERYTHING possible

www.heimatec.de
Produkte / u-tec

www.heimatec.com
products / u-tec

► Ausführungen siehe Katalog
versions see catalogue



► **Zubehör**
accessories



► Ausführungen siehe Katalog
versions see catalogue



www.heimatec.de
Produkte / Zubehör

www.heimatec.com
products / accessories

Notizen
notes

heimatec®

- heimatec®-Niederlassungen
heimatec® overseas branches
- unsere weltweiten Vertretungen
global representations of heimatec®

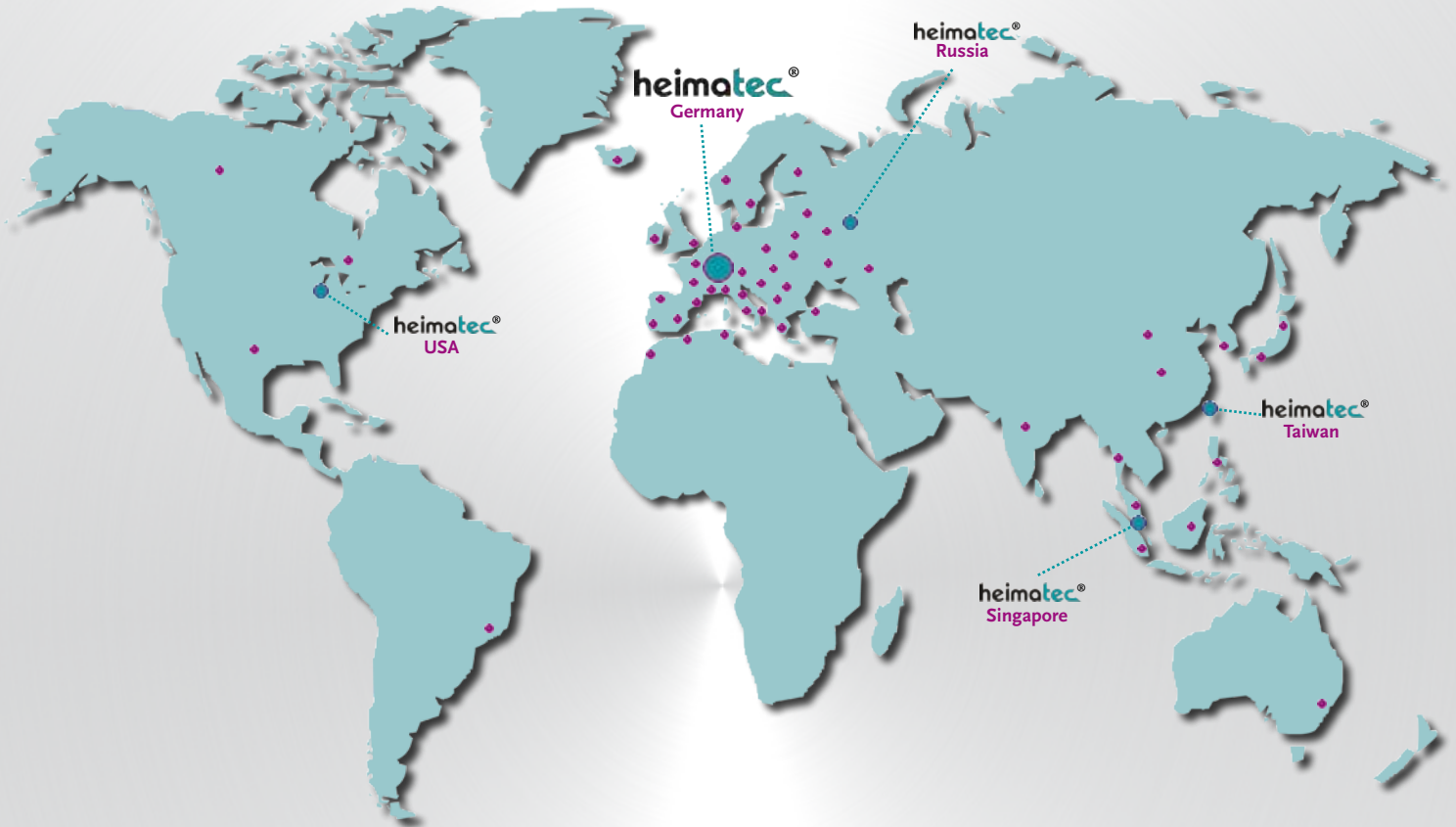

Hauptsitz/headquarters

heimatec® GmbH
Präzisionswerkzeuge
Carl-Benz-Straße 4
D- 77871 Renchen
Postfach 11 36
D- 77867 Renchen
Tel.: +49 (78 43) 94 66 0
Fax: +49 (78 43) 94 66 66
heimatec.de
info@heimatec.de

heimatec® Inc.
USA
usa.heimatec.com
USA@heimatec.com

heimatec®-Ost, JSC
Russia
ru.heimatec.com
Russia@heimatec.com

heimatec® Ltd.
Taiwan
tw.heimatec.com
Taiwan@heimatec.com

heimatec®
Singapore
sg.heimatec.com
Singapore@heimatec.com

